

SOLARMODEL1

Modular Lithium Solar Station (AIO)

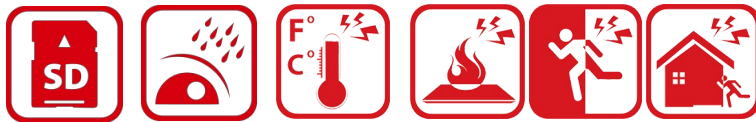

Key Features

The AIO Modular Lithium Solar Station is fully customisable according to the project requirements. Coming standard with a 100W Monocrystalline Silicon Panel and a 460WH Lithium slimline Battery integrated in the bracket of the solar panel. Inbuilt heating element allows the solar panel to charge the Lithium battery at low temperatures. This solution is suitable for Parks, Rural, commercial, government, building industry etc

- 100W Monocrystalline Panel
- 460WH Lithium Battery (Built in bracket)
- Built in Heating element
- Optional 4G WiFi Industrial modem
- Optional Pole 4-8m (plastic coated Q235 Steel)
- Optional Wifi Long range P2P
- Outdoor rated IP66
- Customisable with all Hik/Dahua Cameras
- 3 Year warranty

Specifications

Solar Panel / Battery summary	
Size Battery	205x112x68mm
Module	100W
Battery	Lithium Ion - 460WH
Load Voltage	10 ~ 14.6V
Max Charge	10A
Solar Input Voltage	18V
Max Load	40W
Panel	
Solar Cell	156Mono
Optimum Power(V)	18V
Optimum operating Current	5.55
Short Circuit Voltage	6.11
Open Circuit Voltage	21.24
Size Module	940*740*100mm
Front Glass Thickness	3.2mm
Tolerance Watts	±3%
Surfacer Max Load Capacity	60m/s (5kg / sq.m)
Allowable Hail Load	23m/s ,7.53g
Temperature range	-40°C to +85°C
Weight Per Piece(KG)	38KG with Battery (no Pole or accessories)
Cell Efficiency	21.6%
Warranty	90% for 10 years, 80% for 25 years*
Battery	
Array Mode	3S20P
Nominal Capacity	40000mAh
Minimum Capacity	≥39800mAh
Nominal Voltage	11.1V
AC Impedance Resistance	≤200mΩ (AC 1kHz)
Operating Temp	0°C ~50°C (Charging) / -10°C ~60°C Discharging Operating
Cycle Life	≥500*

Dimensions

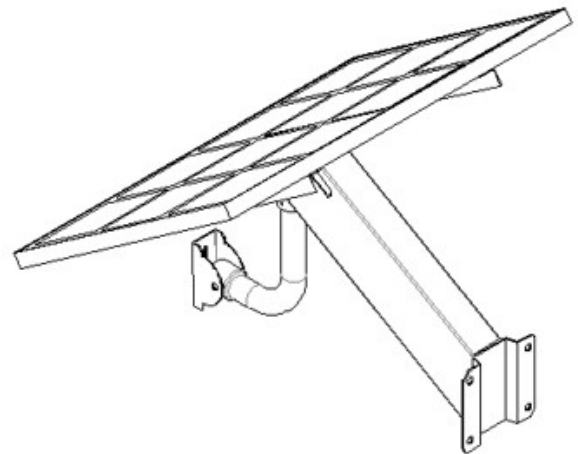
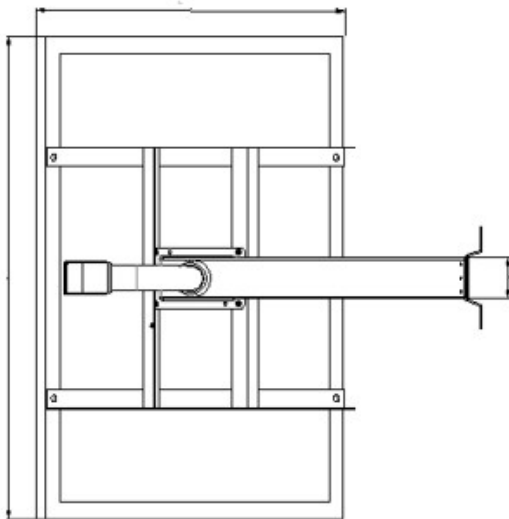
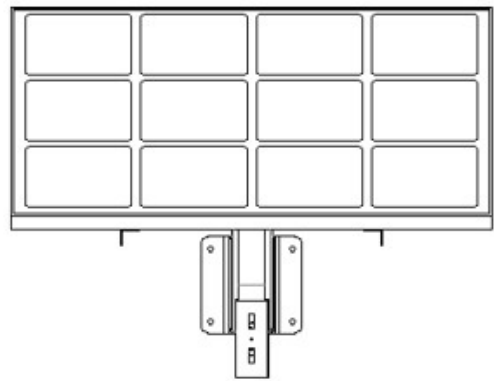
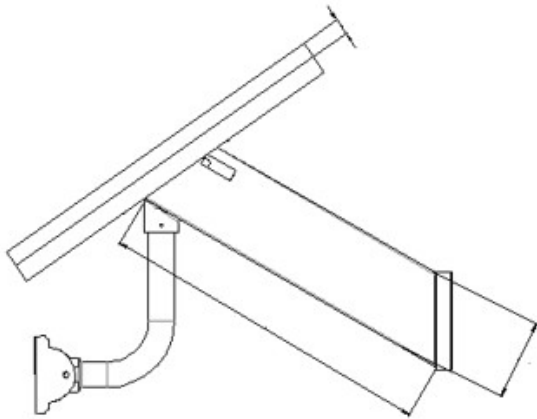

2021 All Rights Reserved. White papers, data sheets, quick start guides, and/or user manuals are for reference only and may or may not be entirely up to date or accurate based upon the version or models. Product names mentioned herein may be the registered and/or registered trademarks of their respective owners